

Network Video Recorder



Key Features

- Support Ultra 265/H.265/H.264 video formats
- 32-channel input
- Third-party IP cameras supported with ONVIF conformance: Profile S, Profile G, Profile T
- VGA and HDMI independent outputs provided
- Up to 8 Megapixels resolution recording
- 4 SATA HDDs, Up to 10TB for each HDD
- Various fisheye dewarping modes for live view and playback for both web interface and GUI
- Support for 12V Power output
- Plug & Play with up to 16 independent PoE network interfaces
- ANR technology to enhance the storage reliability when the network is disconnected
- Support cloud upgrade

Specifications

Model	SST-NVR-NUVO-32P
Video/Audio Input	
IP Video Input	32-ch
Two-way Audio Input	1-ch, RCA
Network	
Incoming Bandwidth	160Mbps
Outgoing Bandwidth	64Mbps
Remote Users	128
Protocols	P2P, UPnP, NTP, DHCP, PPPoE
Video/Audio Output	
HDMI/VGA output	HDMI: 4K (3840x2160@30), 1920X1080@60, 1920X1080@50, 1600X1200@60, 1280X1024@60, 1280X720@60, 1024X768@60 VGA: 1920X1080@60, 1920X1080@50, 1280X1024@60, 1280X720@60, 1024X768@60
Recording Resolution	8MP/6MP/5MP/4MP/3MP/1080p/960p/720p/D1/2CIF/CIF
Audio Output	1-ch, RCA
Synchronous Playback	32-ch
Corridor Mode Screen	3/4/5/7/9/10/12/16/32
Decoding	
Decoding format	Ultra 265, H.265, H.264
Live view/Playback	8MP/6MP/5MP/4MP/3MP/1080p/960p/720p/D1/2CIF/CIF
Capability	2 x 4K@30, 4x 4MP@30, 5 x 3MP@30, 8 x 1080P@30, 16 x 720P@30, 32 x D1@30
Hard Disk	
SATA	4 SATA interfaces
Capacity	up to 10TB for each HDD
External Interface	
Network Interface	1 RJ45 10M/100M/1000M self-adaptive Ethernet Interface
Serial Interface	1 x RS485
USB Interface	Front panel: 2 x USB2.0 Rear panel: 1 x USB3.0
Alarm In	16-ch
Alarm Out	4-ch
Power Output	12 VDC
PoE	
Interface	16 independent 100 Mbps PoE network interfaces
Max Power	Max 30W for single port Max 240W in total (12.5W for each)
Supported Standard	IEEE 802.3af/at
General	
Power Supply	100 ~ 240 VAC Power Consumption: ≤ 20 W(without HDD)

Working Environment	-10°C ~ + 55°C (+14°F ~ +131°F), Humidity ≤ 90% RH(non-condensing)
Dimensions(W×D×H)	400 mm× 362mm×74mm (17.4" × 16.7"×3.4")
Weight (without HDD)	≤ 5 Kg (11.02 lb)

Dimensions

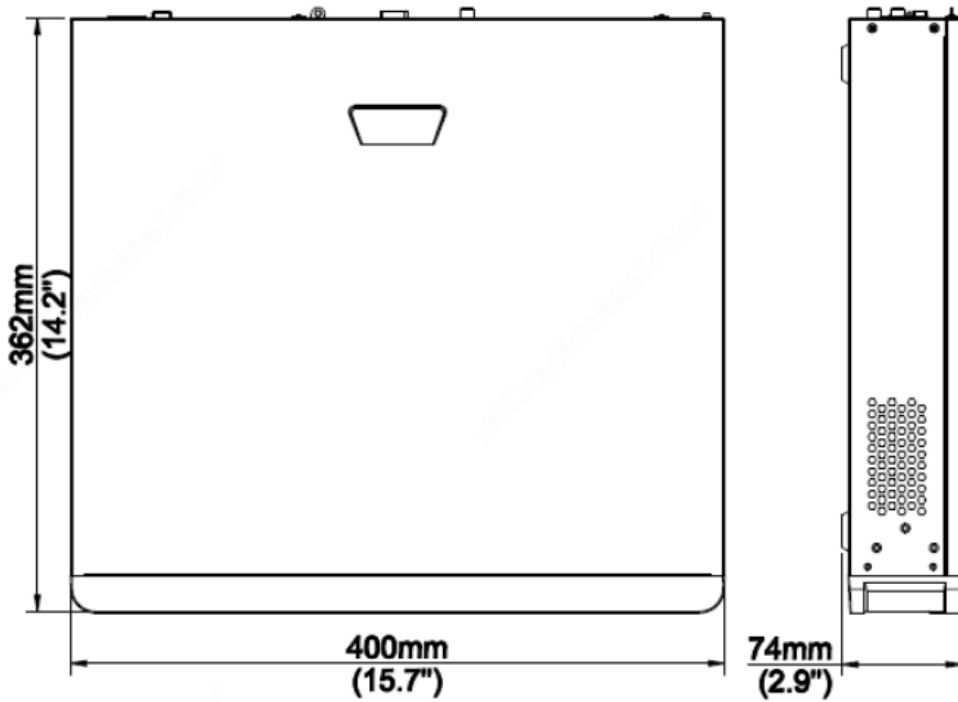

Rear Panel

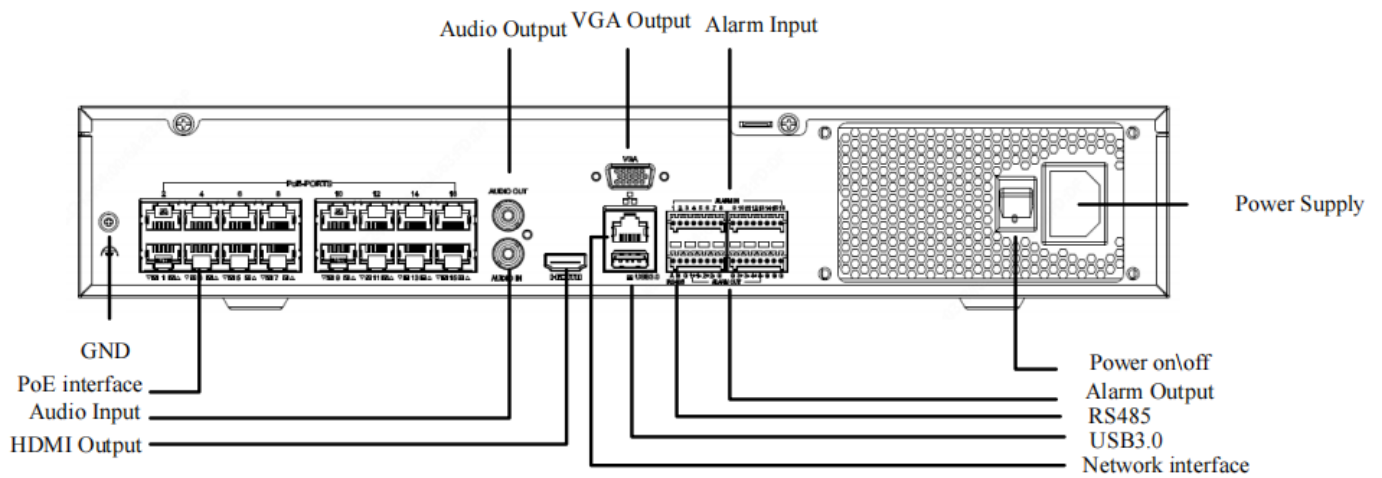

*Product specifications and availability are subject to change without notice.